



Magswitch Technology, Inc.
 8774 Yates Dr. Suite 140
 Westminster, CO 80031
 Magswitch.com.au
 303-468-0662

Magswitch 90 Degree Angle 165

P/N: 8100548

Magswitch 90 degree Welding Angles are the most versatile in the market. Featuring the benefits of Magswitch including incredible power and precision control, the Magswitch 90 degree angles are easy to use, and can be used with larger and heavier steel. All Magswitch 90 degree angles allow you to reposition the magnets up or down on each axis, or reverse from outside to inside. If you want more strength, just add more Magswitch MagSquares.



WARNING!
Do Not Operate Unless In
Contact With Ferrous Target

SPECIFICATIONS	
P/N: 8100548 - MAGSWITCH 90 Degree Angle 165	
Max Breakaway*	150 lbs/68 kg
Full Saturation Thickness	0.25"/ 6 mm
2:1 Shear Working Load*	18.5 lbs/8.4 kg
Net Weight	1.8 lbs/0.8 kg
Overall Height	205 mm
Magnetic Pole Footprint	48mm x 31mm

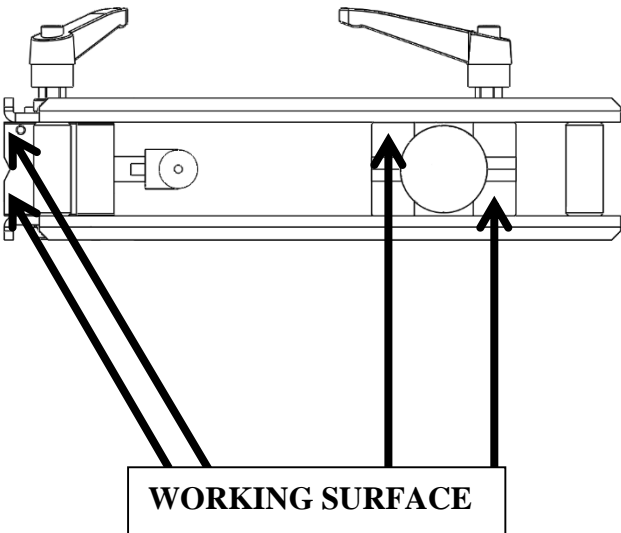

* Max Breakaway determined in laboratory environment on 2" thick SAE1018 Steel with surface roughness 63 micro inches. Many factors contribute to the actual breakaway force in each application. Always test the magswitch in each application before deployment. Refer to the magswitch information booklet for more information.



Magswitch 90 Degree Angle 165 Breakaway Data vs. Thickness

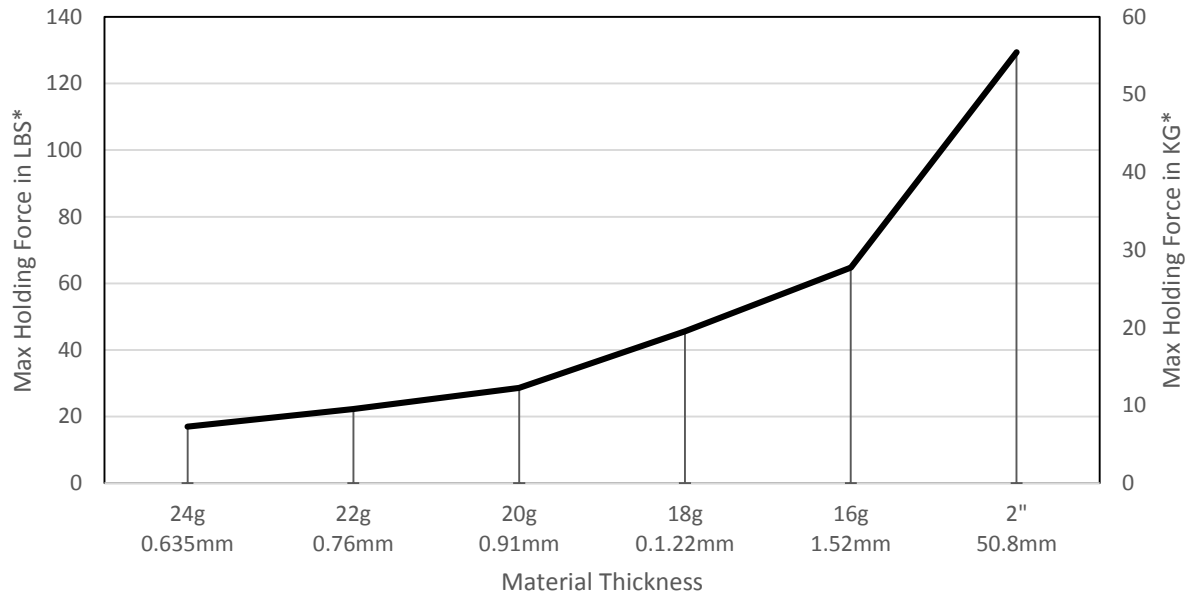



Part Number 110897
 Revision Date: October, 16 2013

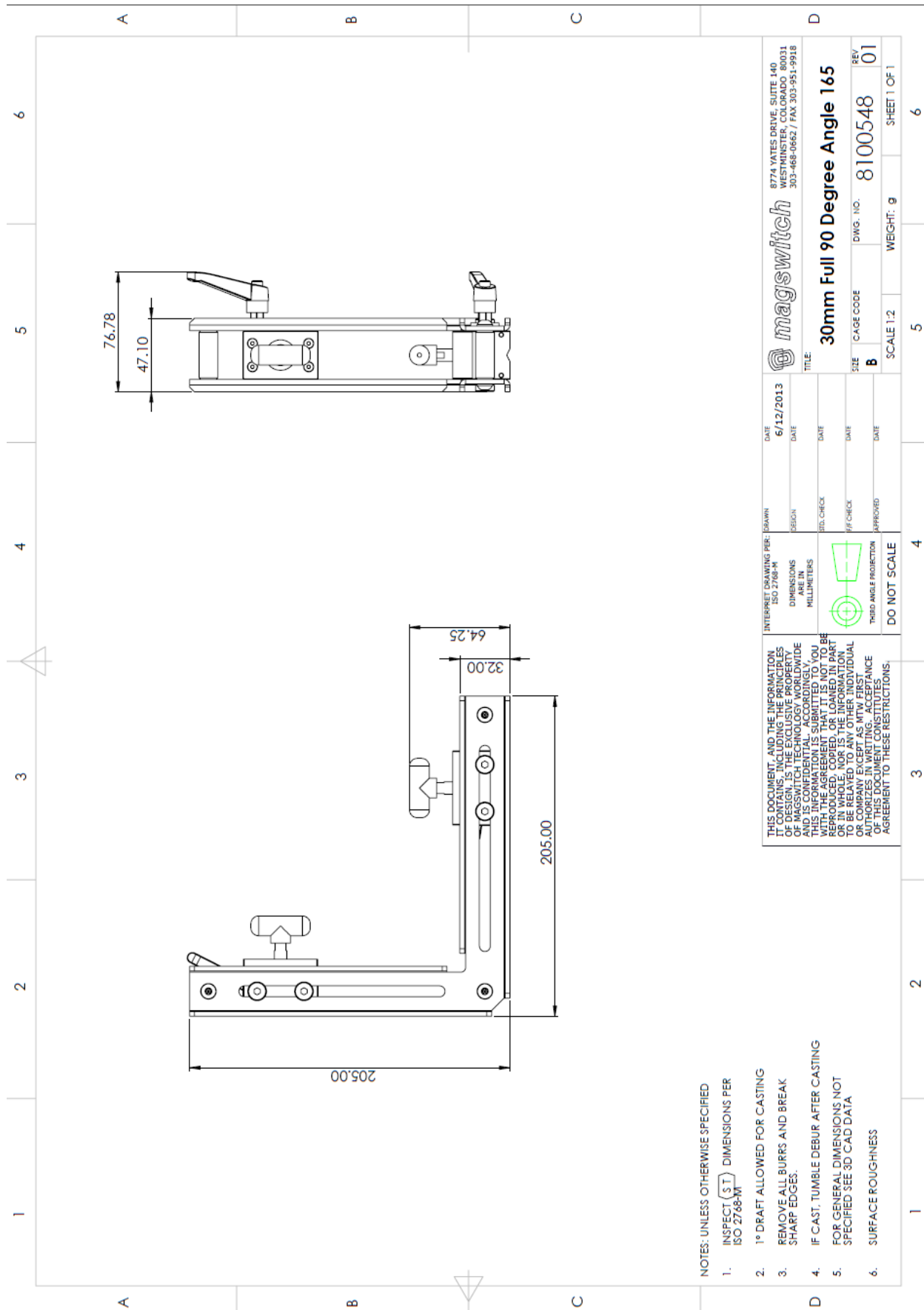

NOTES: UNLESS OTHERWISE SPECIFIED

1. INSPECT (S T) DIMENSIONS PER ISO 2768-M
2. 1° DRAFT ALLOWED FOR CASTING
3. REMOVE ALL BURRS AND BREAK SHARP EDGES.
4. IF CAST, TUMBLE DEBUR AFTER CASTING
5. FOR GENERAL DIMENSIONS NOT SPECIFIED SEE 3D CAD DATA
6. SURFACE ROUGHNESS

INTERPRET DRAWING PER: DRAWN ISO 2768-M DIMENSIONS MILLIMETERS		DATE	6/12/2013
DESIGN		DATE	
STD. CHECK		DATE	
I/F CHECK		DATE	
APPROVED		DATE	
THIRD ANGLE PROJECTION 		DO NOT SCALE	
THIS DOCUMENT, AND THE INFORMATION CONTAINED HEREIN, IS THE PROPERTY OF MAGSWITCH TECHNOLOGY WORLDWIDE AND IS CONFIDENTIAL. ACCORDINGLY, IT IS NOT TO BE REPRODUCED, COPIED, OR LOANED IN PART OR IN WHOLE, NOR IS THE INFORMATION TO BE DISCLOSED TO ANY INDIVIDUAL OR COMPANY EXCEPT AS AUTHORIZED BY THE COMPANY IN WRITING. ACCEPTANCE OF THIS DOCUMENT CONSTITUTES AGREEMENT TO THESE RESTRICTIONS.		TITLE 30mm Full 90 Degree Angle 165	
SIZE B	CAGE CODE 8100548	DWG. NO. 8100548	REV 01
SCALE 1:2		WEIGHT: g SHEET 1 OF 1	

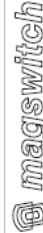

30mm Full 90 Degree Angle 165

8774 YATES DRIVE, SUITE 140
 WESTMINSTER, COLORADO 80031
 303-468-0662 / FAX 303-951-9918